

CLXSA016KA8

Smart Card

DESCRIPTION

The CardLogix CLXSA016KA8 Smart Card incorporates a 16,384 bit Serial Electrically Erasable PROM in a 2,048 by 8 architecture. This card is for advanced, low power applications such as small record storage and loyalty applications where low cost is a driving factor.

The CLXSA016KA8 offers a straight memory array that features ultra-high-endurance EEPROM for data that changes frequently. The entire array is rated at 1,000,000 ERASE/WRITE (E/W) cycles guaranteed. The CLXSA016KA8 advanced CMOS technology makes this device ideal for low-power non-volatile code and data applications.

Program development is supported through the Smart Toolz™ development kit, the Cardplex™ API and CardAppz™ application software.

The CLXSA016KA8 is available in the ISO 7816 standard, and CR80 package.

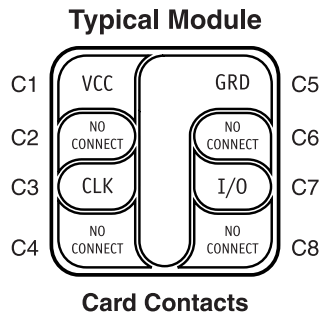

FEATURES

- Voltage operating range: 2.5V to 5.5V
 - Peak write current 3 μ a at 5.5V
 - Maximum read current 150 μ a at 5.5V
 - Standby current 1 μ a typical
- Industry standard two wire bus protocol
 - I²C™ compatible
- 16-byte page, or byte modes available
- 1 ms typical write cycle time, byte or page
- Includes 100 KHz (2.7V) and 400 KHz (5.0V) Compatibility
- Filtered inputs for noise suppression
- Power on/off data protection circuitry
- Endurance: 1,000,000 E/W cycles guaranteed
- Electrostatic discharge protection > 4,000V
- Data retention > 100 years

Figure 1. Block Diagram

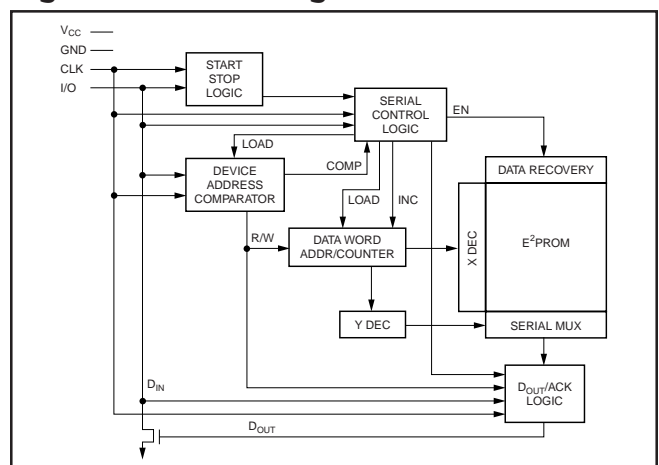

16 Hughes, Suite 100 • Irvine, California 92618 • Ph:(949) 380-1312 • Fax:(949) 380-1428

Preliminary Information: © 1998 CardLogix, Inc. All information is preliminary, and CardLogix retains the right to change and/or withdraw any portion without notice. This document and its contents are covered under U.S copyright and register laws, all rights reserved. DCTB-CLXSA016KA8-99c 05/04/99