

Technical Brief

CLXSU064KF6/T=0ED**M.O.S.T. Card™****DESCRIPTION**

The CardLogix CLXSU064KF6/T=0ED smart card features a powerful embedded 32 bit microcontroller and the M.O.S.T. card operating system. The card includes advanced password security logic, dynamic DES encryption, authentication, and a file management system. This card is designed for single and multiple use applications such as record storage, encrypted keys and stored value. The CLXSU064KF6/T=0ED Smart Card provides the systems designer with the greatest degree of flexibility needed from microprocessor cards.

The card features a 64K-bit user memory (EEPROM), a hardware random number generator, and 256 bytes of RAM. It also features an ISO 7816-3, asynchronous T=0 interface which works with all standard T=0 readers. Program development is supported through the M.O.S.T. Toolz™ Development Kit, the Winplex® API, ISO Standard Protocols and the PC/SC Interface. Access to the card can be controlled by either factory setting or user generated passwords.

The card is completely programmable for limiting access to the card or specified files. All files created can be specified to have one of three access controls; "Always", "Never" and "With Permission". Retry counters can be used to track the number of incorrect password/authentication accesses to the CLXSU064KF6/T=0ED. This mechanism prevents all further accesses to the files, as soon as the number of incorrect accesses exceeds the value in the retry register. A nonvolatile "kill bit" prevents further tampering.

The card is available in the CR-80, SIM/SAM and KeyFab sizes with standard ISO 7816 pin outs.

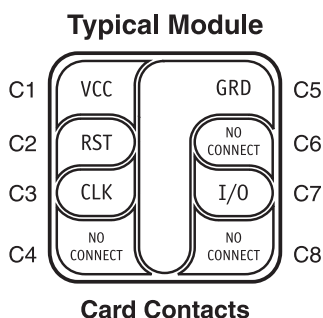
**FEATURES**

- Operating Voltage range: 3V to 5V
- Ultra low power CMOS (<100µA standby, <3mA active)
- Dynamic DES encryption for secure data transactions
- Full SHA1 Authentication
- Each file can be read and write protected
- Triple layer programmable password security
- User memory is reconfigurable an unlimited number of times, with protected programmable passwords
- ATR configuration and T=0 serial interface in accordance with ISO standard 7816 (asynchronous transmission)
- Data retention > 100 years
- Endurance: Minimum of 10⁵ write/erase cycles
- Electrostatic discharge protection > 4,000V
- Optional high speed communications "PTS" negotiated mode up to 115K baud

**M.O.S.T. CARD OPERATING SYSTEM
COMMAND SUMMARY****Security Commands**

VERIFY	CHANGE_CODE
INVALIDATE	REHABILITATE
GET_CHALLENGE	INTERNAL_AUTH
EXTERNAL_AUTH	USER_AUTH(alias)
SECURE_READ	SECURE_WRITE
SET_KEY	GENERATE_KEY
SET_ENCRYPTION	UPDATE_SECURE

Operational Commands

SELECT	READ_BINARY
GET_RESPONSE	WRITE_BINARY
UPDATE_BINARY	

CardLogix Commands

CLX_PURSEWDL	CLX_PURSEDEP
CLX_PURSEVAL	



Full specification available under a CardLogix non-disclosure agreement.

(Reference #9 000 285)

16 Hughes, Suite 100 • Irvine, California 92618 • Ph: (949) 380-1312 • Fax: (949) 380-1428

Preliminary Information: © 2005 CardLogix, Inc. All information is preliminary, and CardLogix retains the right to change and/or withdraw any portion without notice. This document and its contents are covered under U.S copyright and register laws, all rights reserved.

DCTB-CLXSU064KF6/T=0ED 7400007 - 02172005